

# C x L Laboratory Microscopy

## User Manual

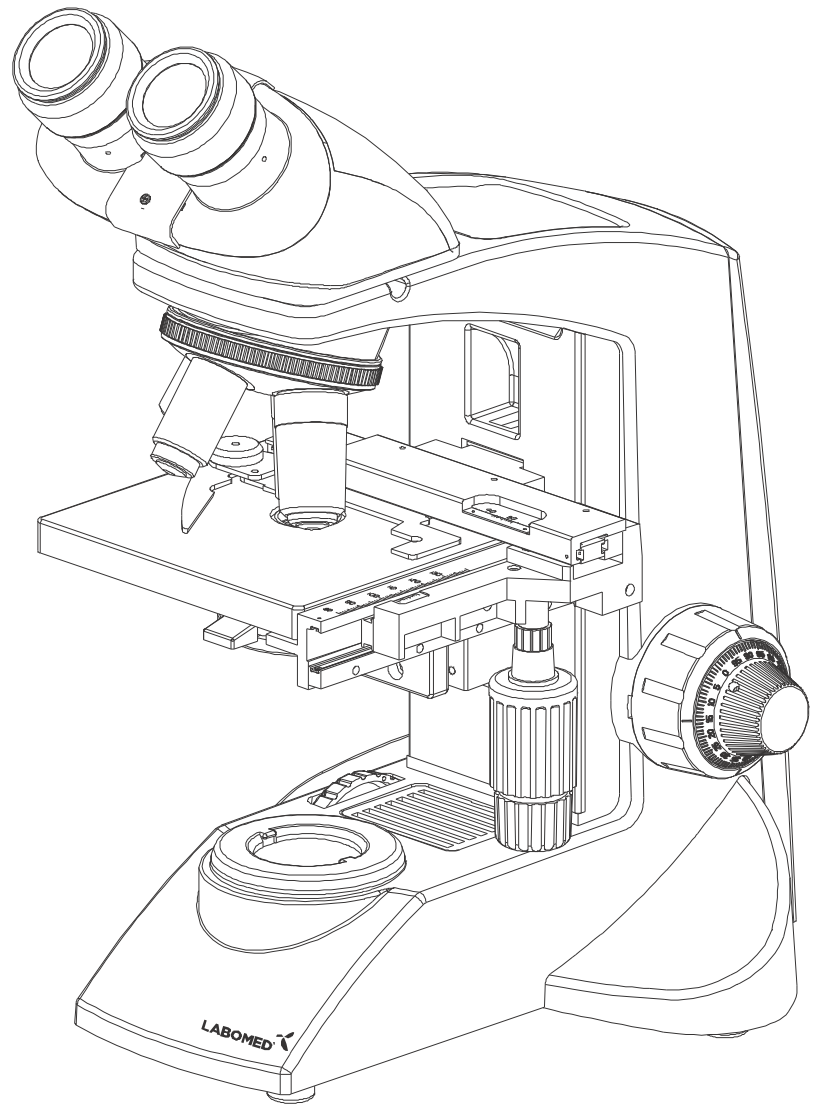

To ensure proper use of this instrument as well as to avoid injury while operating Instrument, understanding this manual completely before use is highly recommended.

Part No: 9135000-795  
Issue 1.7  
Printed on April,2022

# TABLE OF CONTENTS

<b>1. INTRODUCTION</b>	<b>1</b>
<b>2. SAFETY INFORMATION</b>	<b>2-5</b>
GETTING STARTED	
MAINTENANCE & STORAGE	
CAUTION	
CARE & MAINTENANCE	
CLEANING & DISINFECTION	
<b>3. CxL MONOCULAR</b>	<b>6</b>
<b>4. CxL BINOCULAR</b>	<b>7</b>
<b>5. CxL TRINOCULAR</b>	<b>8</b>
<b>6. UNPACKING YOUR MICROSCOPE</b>	<b>9</b>
<b>7. STANDARD COMPONENTS</b>	<b>10</b>
<b>8. OPTIONAL ACCESSORIES</b>	<b>11-12</b>
<b>9. INITIAL SETUP</b>	<b>13</b>
<b>10. REPLACEMENT OF CRITICAL COMPONENTS</b>	<b>14-15</b>
<b>11. SUMMARY OF BRIGHT FIELD OBSERVATION PROCEDURE</b>	<b>16</b>
<b>12. DETAILED OBSERVATION PROCEDURE</b>	<b>17-21</b>
<b>13. TROUBLESHOOTING GUIDE</b>	<b>22-23</b>
<b>14. SPECIFICATIONS</b>	<b>24</b>

The CxL is a laboratory microscope reflecting a modern design as well as the latest in optical and mechanical advancements.

Designed for professionals as well as students, this microscope offers many features and functions for a diverse set of applications.

Extra clarity and contrast is provided through a 360° rotatable Monocular/Binocular/Trinocular body inclined at 45°.

The pressure die cast stand consists of Ball bearing 'frictionless' sideways focusing to avoid any loss in motion.

The sturdy new stylish design provides comfort as well as stability.

The high powered objectives are spring loaded to prevent accidental damage to specimen slides.

The quadruple nose piece has a comfortable ribbed grip for easy rotation that also safeguards the turret system against any damage. All positions are par-centered and par-focalised ensuring the highest level of accuracy.

The ball bearing mechanical stage allows smooth travel over a 76 x 50mm area with spring loaded stage clamps for retaining the specimen at the exact position desired. A 0.1mm vernier scale provides accurate location of specimen area.

The LED configuration is operational with an in-built rechargeable battery and charging circuit. The battery will be charged with a direct input power supply of 110V-240V AC 50Hz/60Hz. This ensures continuous operation even under fluctuation voltages.

Our Halogen bulb (6V-20W) has an average life span of upto 2,000 hours. Our LED has an average life span of upto 50,000 hours.

The CxL comes equipped with a removable N.A. 1.25 Abbe condenser for brighter illumination levels, and an diaphragm for better resolution and contrast control.

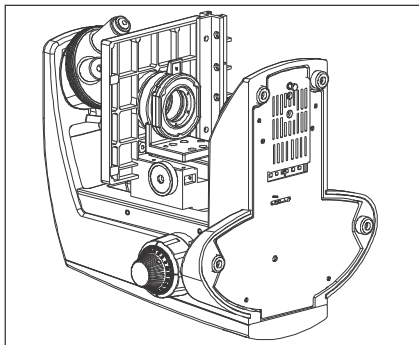

Fig. 1

1. After the microscope has been used for observation of a specimen containing bacteria, clean all parts coming in contact with the specimen to prevent infection.
  - Be sure to remove the specimen before moving this product.
  - In case the specimen is damaged by erroneous operation, it is important to clean all surfaces that may have come in contact with the specimen.
2. To avoid potential electrical hazards when replacing either halogen bulb or LED, turn the microscope main switch to the OFF position and disconnect power cord from wall outlet in advance. Whenever you replace your microscope bulb, allow lamp socket and bulb to cool before touching (Fig.1)
3. Install microscope on a sturdy, level table or bench and avoid any restriction of air vents in the base of the unit.
 

Do not place microscope on a flexible surface, as this could result in blocking the air vents and cause overheating.
4. Always use the power cord provided by LABOMED. If the proper power cord is not used, product safety performance cannot be warranted.
5. When installing the microscope, route the power cord away from the microscope frame. Should the power cord come in contact with the microscopes base, the power cord could melt due to overexposure to heat.
6. Always ensure that the grounding terminal of the microscope and that of the wall outlet are properly connected. If the unit is not grounded, LABOMED can not warrant electrical safety.
7. Never allow metallic objects to penetrate the air vents of the microscope frame as this could result in user injury and damage to the microscope.
8. After operation of microscope, be sure to disconnect power cord from connector socket of the microscope or from the wall power outlet.



## SAFETY SYMBOLS

The following symbols are found on the microscope. For optimal use, it is recommended that users Understand these symbols and always use the equipment as prescribed.

Symbol	Explanation
	This surface has a tendency to heat up and should not be touched unless System has completely cooled down.
	Before use, carefully read the instruction manual. Improper use could result in Injury to the user and/or damage to the equipment.
	Warning against risk of electric shock.
	Main switch is ON.
	Main switch is OFF

**WARNING LABEL**

A warning indication label is attached to every part where special precaution is required while handling and using the microscope. Always read the warnings.

Warning label position	Bottom of microscope frame	[Warning against high temperature in bulb/LED compartment]	
		[Warning against risk of electric shock]	
		[Warning against damage in non-compliance with instructions manual]	

If the warning label is stained or peeled off, contact your LABOMED distributor.

**1 GETTING STARTED**

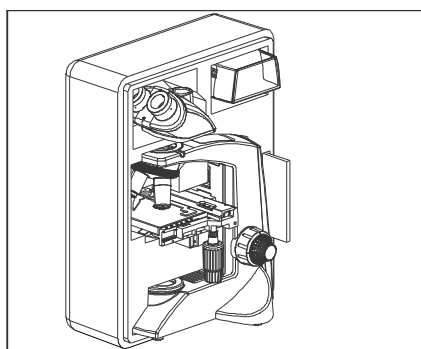

Fig. 2

1. A microscope is a precision instrument with delicate glass components. Please handle with care.
2. Do not use the microscope where it is subjected to direct sunlight, high temperature, humidity, dust and vibrations. ( For the operating conditions, see chapter 14. "SPECIFICATIONS") on Page 24.
3. The microscope is ventilated by natural convection. Be sure to leave enough space (10cm or more) around body when installing the unit.
4. Arm handle is provided for carrying the microscope.  
**To prevent damage, do not hold the microscope by the stage or observation tube.**  
**Be sure to remove the specimen from the stage clip while transporting unit to avoid damage of the specimen slide.**

**2 MAINTENANCE AND STORAGE**

1. Clean all glass components by wiping gently with cleaning cloth provided. To remove fingerprints or oil smudges, wipe with cleaning cloth slightly moistened with a mixture of petroleum (85%) and isopropanol (15%).

Since solvents such as petroleum and isopropanol are highly flammable, they must be handled carefully. Be sure to keep these chemicals away from open flames or potential Sources of electrical sparks - For Example, electrical equipment that is being switched "ON" or "OFF". Also remember to always use these chemicals only in a well-ventilated room.

2. Do not attempt to use organic solvents to clean the microscope components other than the glass components. To clean non-glass components, use a lint-free, soft cloth slightly moistened with a diluted neutral detergent.
3. Do not disassemble any part of the microscope as this could result in malfunction or mitigated performance.

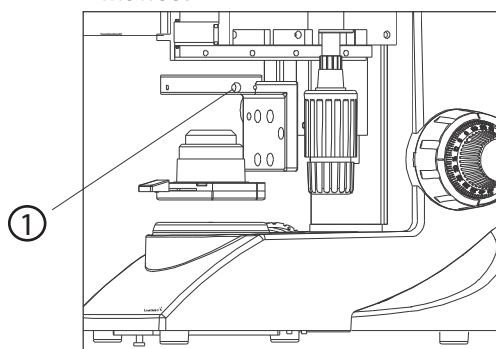

Fig. 3

4. When not using the microscope, ensure that the frame is fully cooled before storing the unit in a dry locker or covering with a dust cover (provided).
5. To clean the condenser/phase turret, fully loosen the securing thumb screw (1) and remove the condenser then, wipe the front lens of the condenser with optical cleaning solution (mixture suggested above) and lens tissue.  
 The condenser can also be re-attached by replacing the condenser in its seat, tightening securing thumb screw, and raising condenser bracket to desired position.
6. Be sure to observe your local rules/regulation for product disposal.

**3**

### 3 CAUTION

If the microscope is used in a manner not specified by this manual, the safety of the user may not be warranted. In addition, the equipment may also suffer damage. Always use the equipment as outlined in this instruction manual.

### 4 CARE & MAINTENANCE

Your microscope had been engineered for a long and safe operational life with the least amount of maintenance required. In general, routine maintenance is limited to keeping the microscope working parts lubricated and optics clean. Always cover the microscope with the provided dust cover when not in use.

#### 1. Cleaning the lenses:

To clean the lens surfaces, remove dust using a soft brush or gauze (compressed air dust cans are ideal). For removing finger marks or grease, soft cotton cloth or lens tissue lightly moistened with cleaning solution (85% petroleum ether and 15% isopropyl alcohol) should be used. For cleaning the optics, use xylene. Observe sufficient caution in handling xylene.

##### Cleaning Procedure:

Place the Objective and/ or eyepieces on a dust free surfaces (e.g. aluminum foil). All other optical components to be cleaned should be as accessible as possible.

- Blow all loose dust particles away with a dust blower.
- Remove all water-soluble dirt with distilled water. If this is unsuccessful repeat using a solution of diluted hand soap liquid. Remove any remaining residue with a dry cotton swab.
- To remove oil, use a solution of diluted hand-soap liquid initially. If this does not produce a satisfactory result, repeat the cleaning using a solvent (Optical Cleaning Solution 85% petroleum ether and 15% isopropyl alcohol).
- Grease must always be removed using a solvent.
- Cleaning is achieved by using a spiral motion from the center to the rim. Never wipe using zig-zag movements as this will only spread the dirt. With larger optical surfaces (e.g. tube lenses) the spiral motion starts initially at the rim before to the middle and is only then followed by a center to rim cleaning motion. Normally several spiral wipes are recommended.

We recommend pure, volatile petroleum ether or Optical Cleaning Solution as explained in point 3 above.

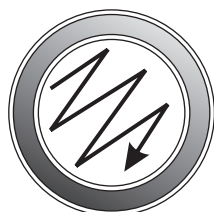

Zig-zag motion (X)



Spiral motion (✓)

Wipe using a spiral movement. Do not use a zig-zag motion!

#### 2. Cleaning of painted surfaces:

Avoid the use of any organic solvent (e.g. thinner, xylene, ether, alcohol etc.) for cleaning of painted surfaces of the instrument. Painted surfaces can be cleaned with a very lightly moistened micro fiber cloth. Loose dust and dirt can be removed using a brush of soft hair used exclusively for this purpose.

**Caution:**

Do not use aggressive organic solvent such as acetone for cleaning painted surfaces and plastic parts of the microscope.

**3. Never attempt to dismantle:**

Never attempt to dismantle the instrument so as to avoid the possibility of impairing its operational efficiency and accuracy.

**4. Periodical checking:**

To maintain the performance of the instrument, we recommend customers have their microscopes serviced periodically by a factory authorized dealer/rep. For details, contact your nearest dealer or Labo America's main office in California.

**5 CLEANING AND DISINFECTION**

**Following disinfectants are recommended for cleaning and disinfection.**

1. Normal household bleach (Sodium hypochlorite 5%)- strength 5000 ppm(10 parts water 1 part bleach).
2. 70% Isopropyl alcohol.

**Procedure:**

- Take a muslin cloth.
- Moist it to feel wet
- Disinfect/clean the surface gently.

**Note – 1. Use mask and Gloves while performing cleaning and disinfection.**

**2. While cleaning, muslin cloth should not be dripped wet to prevent seepage and rusting to running/bare parts.**

**3. Alcohol is flammable, its use as a surface disinfectant should be in well-ventilated spaces only.**

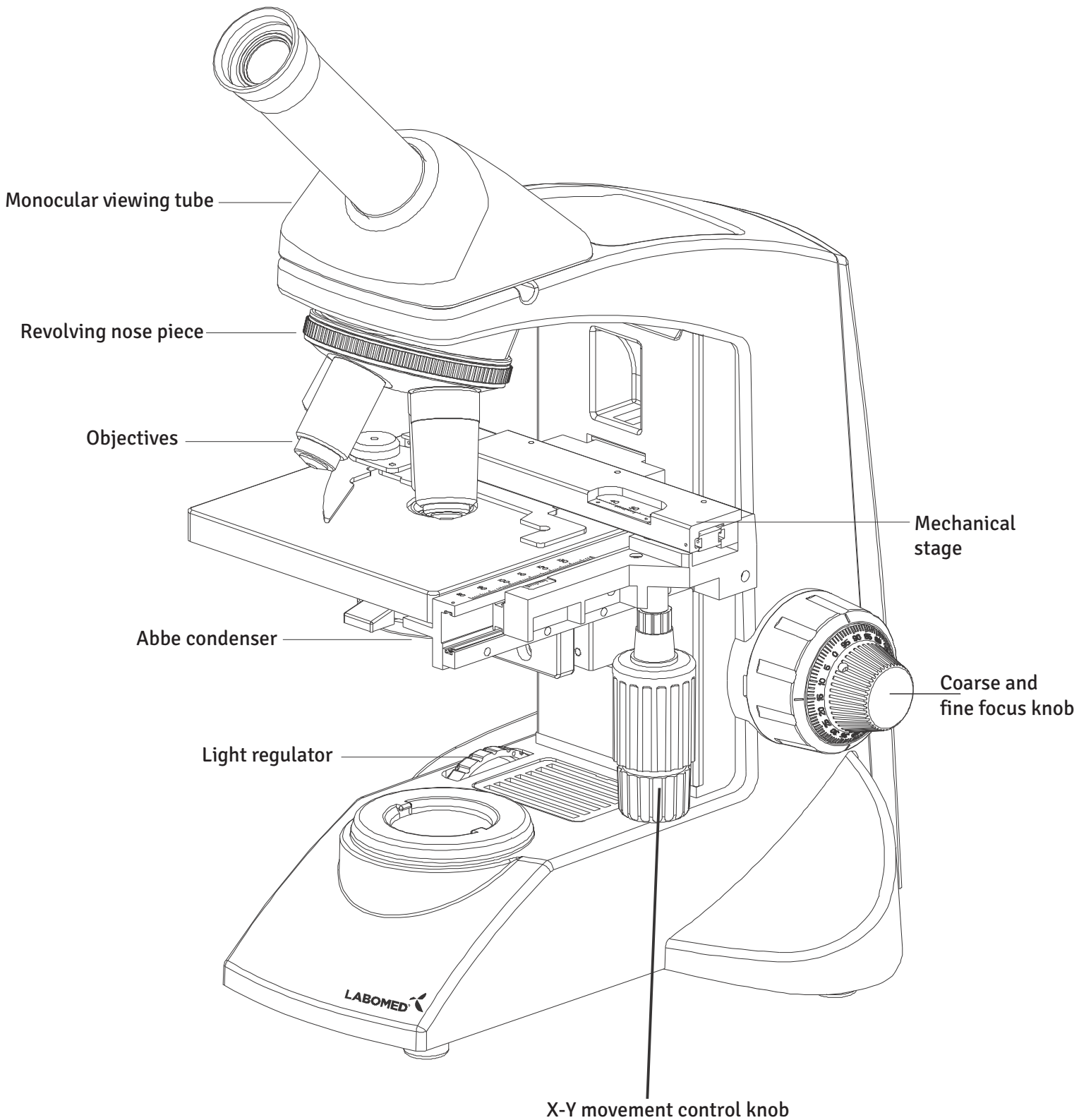



# 4 CxL BINOCULAR

CxL

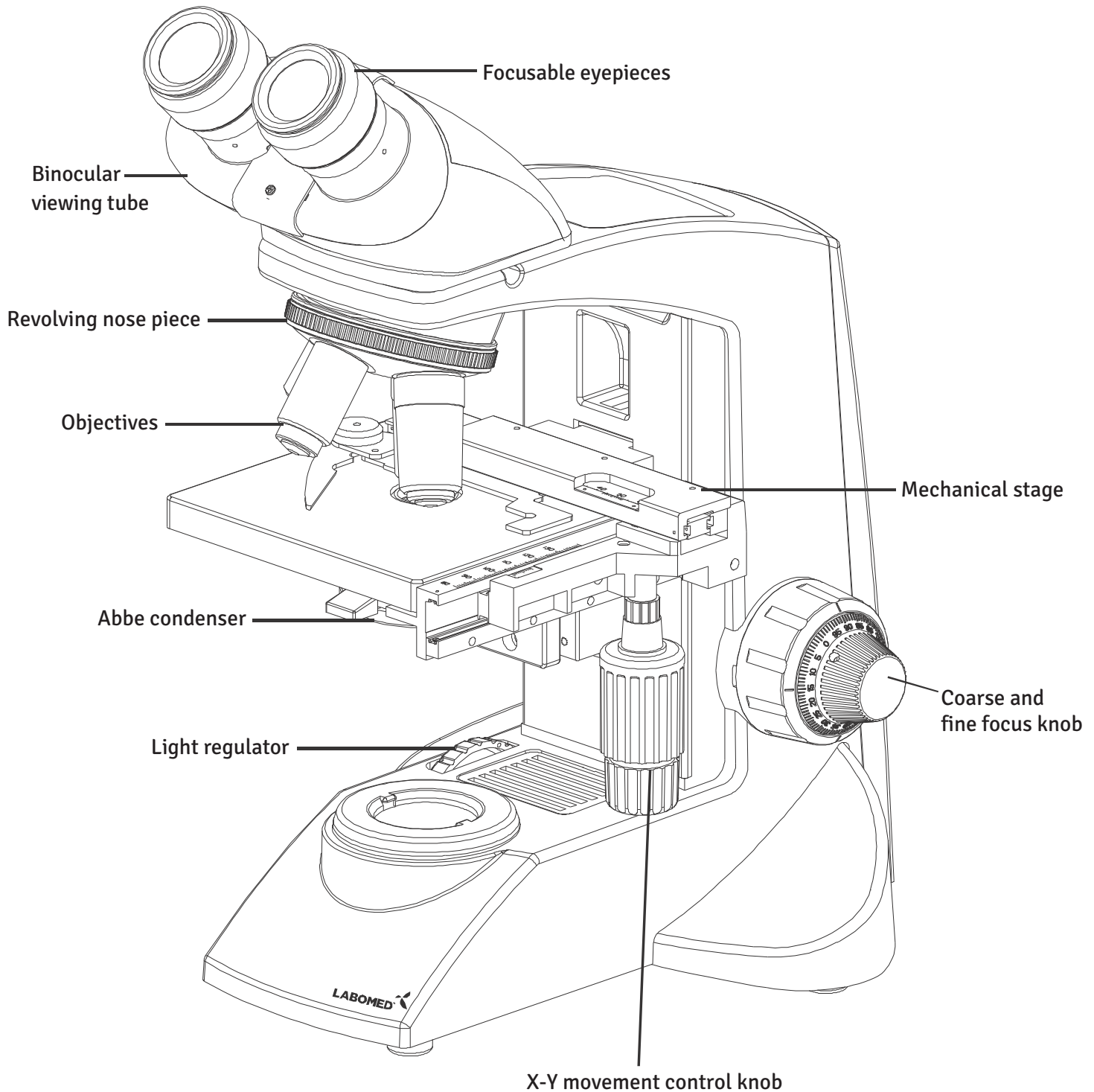

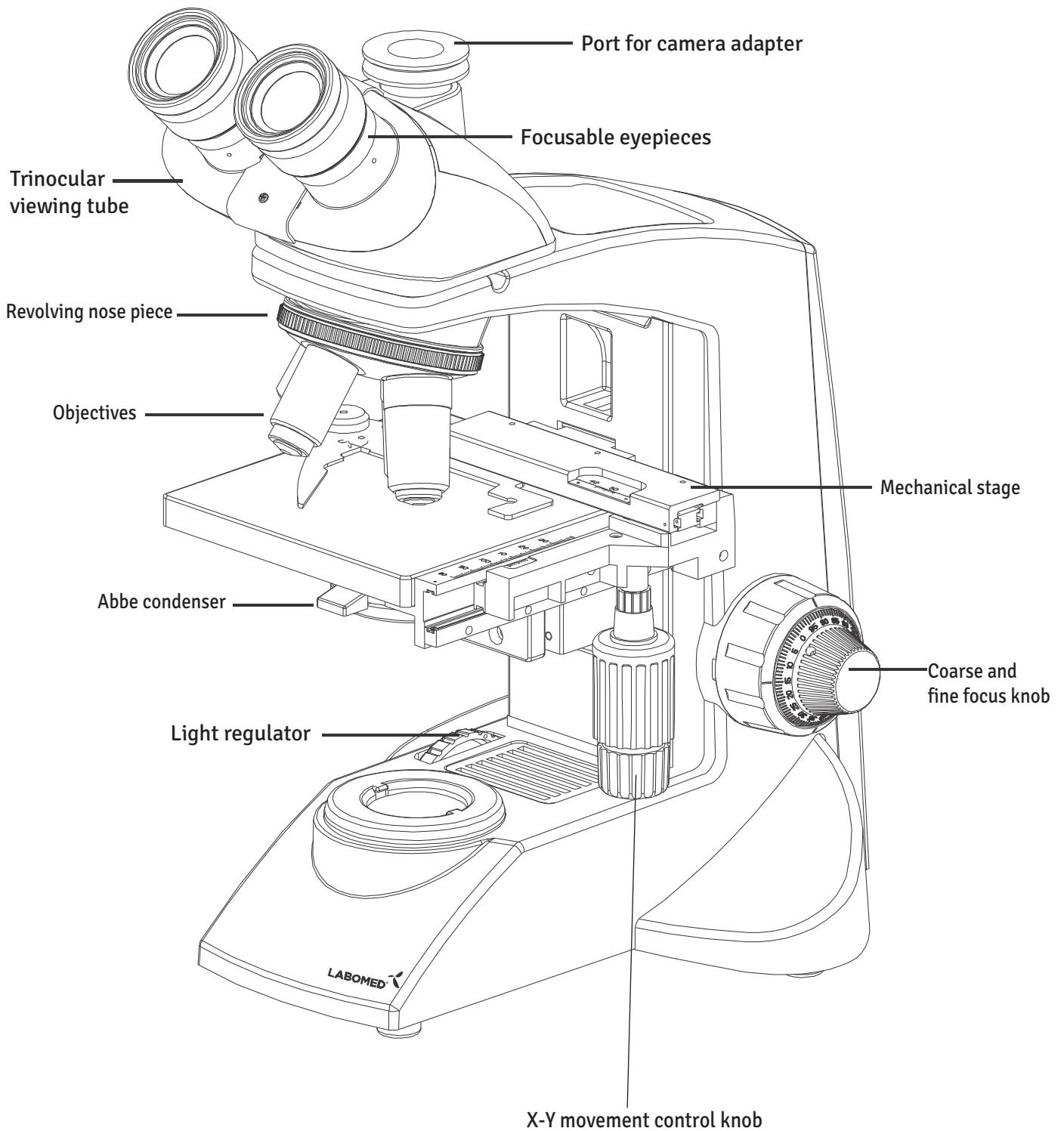

# 6 UNPACKING YOUR MICROSCOPE

CxL

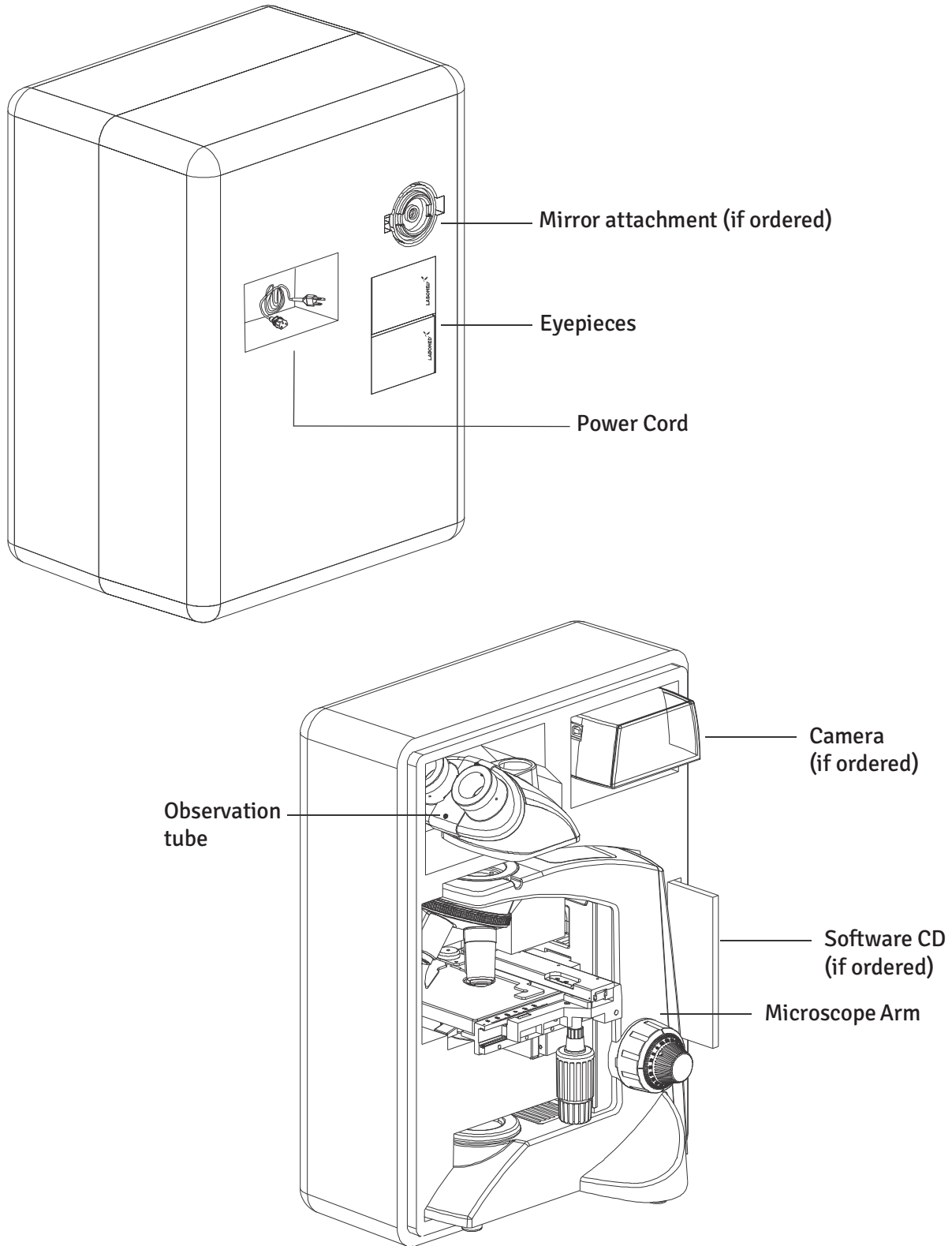

# 7 STANDARD COMPONENTS

CxL

- After removing your microscope from its packaging, make sure that all of the following contents are present.
- The differences in configurations are the number of objectives, type of observation head, type of illumination and purchased optional accessories.
- The objective have been adjusted for a tight fit to prevent any damage during transportation. To remove an objective, rotate it counterclockwise while gripping it with a rubber sheet, etc. to avoid slippage.

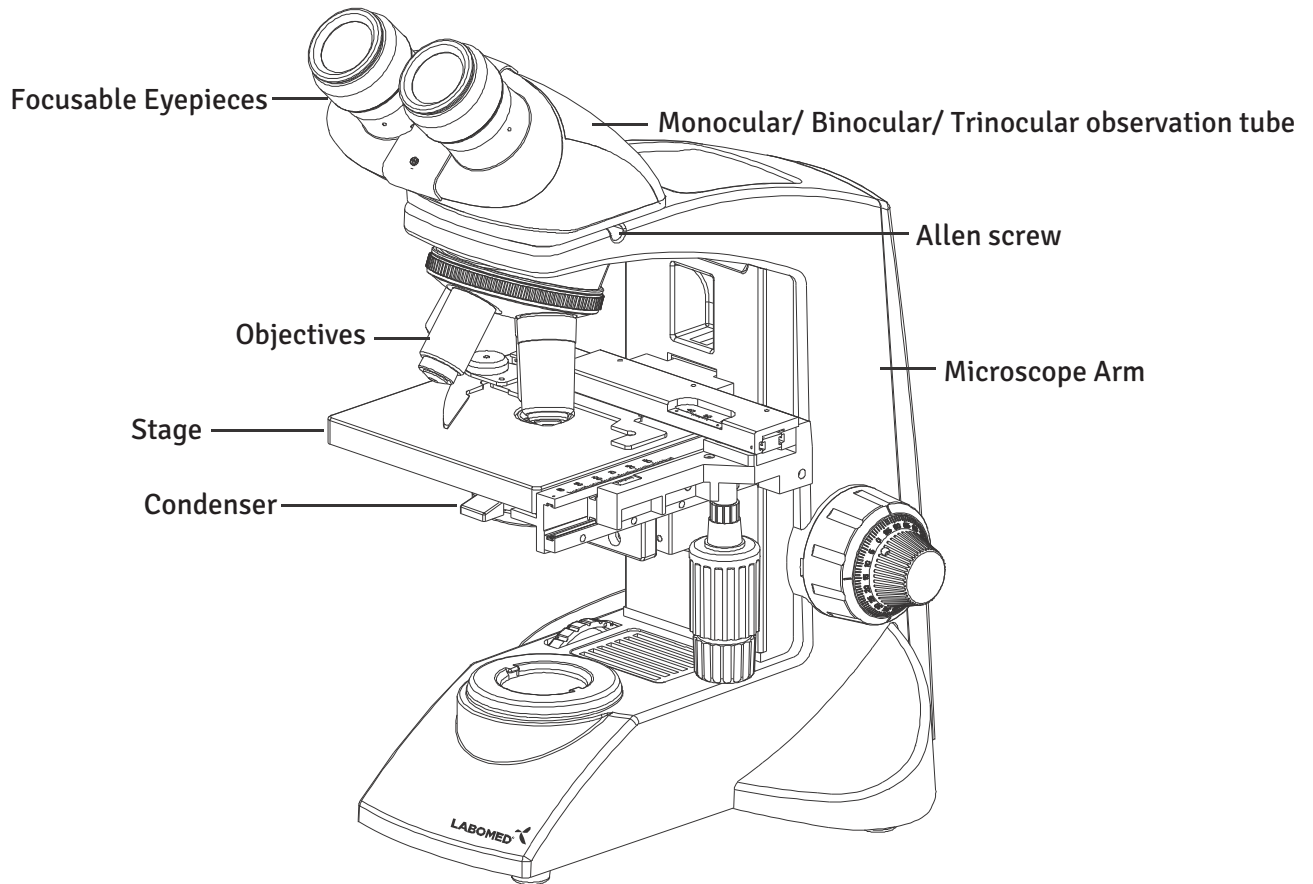

Daylight (blue) filter

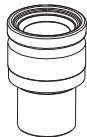

Eyepieces



Allen Wrench 3mm



Allen Wrench 1.2mm

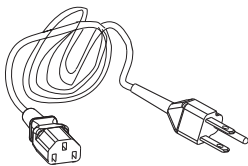

Power Cord



6V 20W Halogen bulb



Spare fuses

SYSTEM DIAGRAM OF OPTIONAL ACCESSORIES

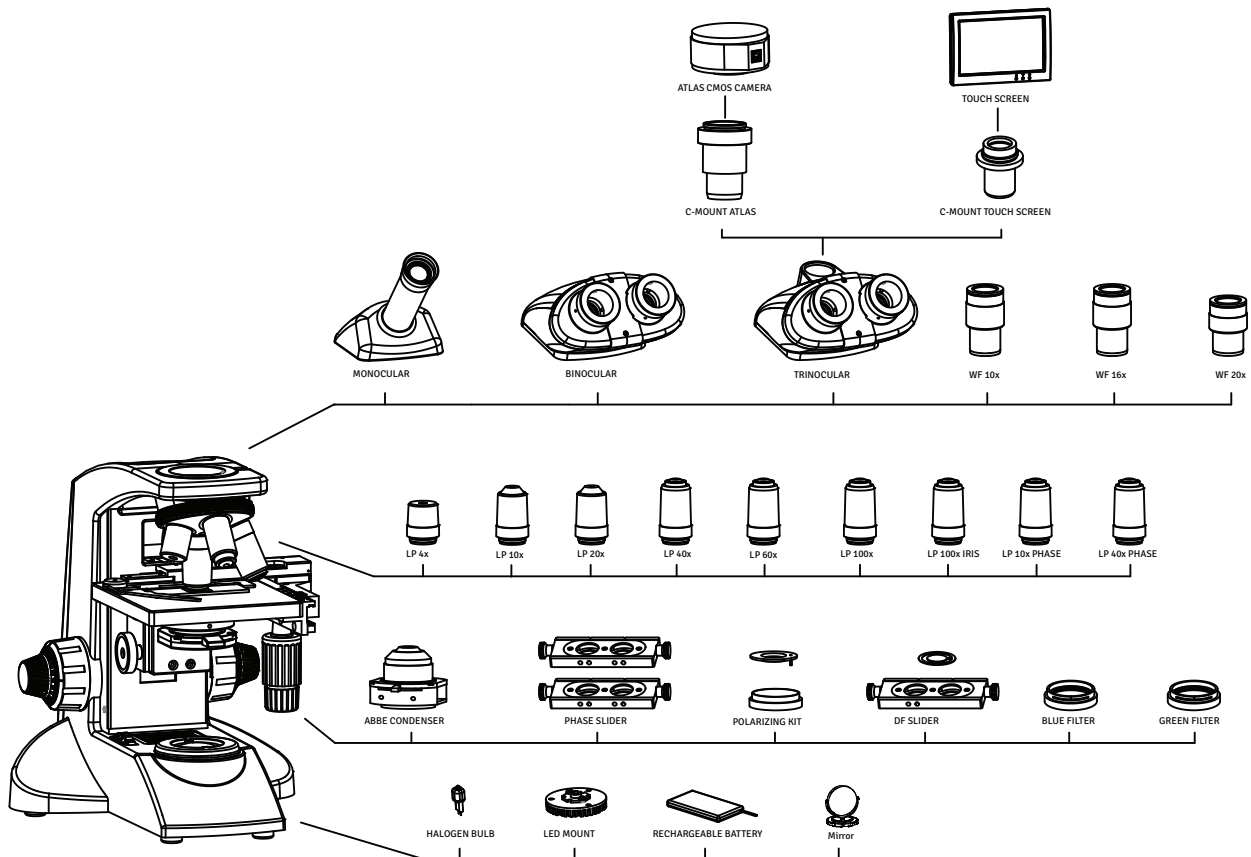

INSTALLATION AND OPERATION OF OPTIONAL ACCESSORIES

1 DARKFIELD SLIDER

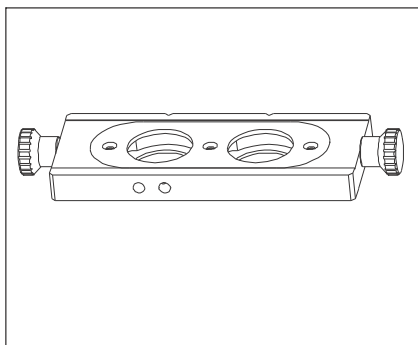

Fig. 4

The darkfield slider enables darkfield observation using an objective from 4X to 40X.

## 2 REFLECTION MIRROR

The reflection mirror is designed to be used in out door observation settings wherein a power source is not readily available. The mirror attachment makes it possible to use natural light to illuminate your specimen.

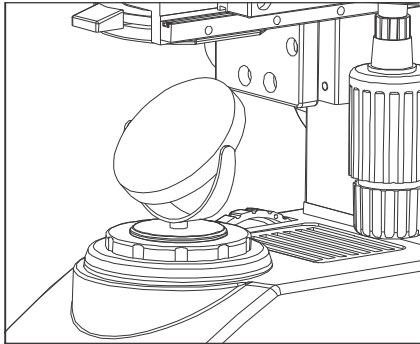

Fig. 5

The microscope should be installed in any place that is not exposed to direct sunlight. Direct sunlight reflection can cause eye injury, or in some cases, blindness.

The eyepieces should be oriented toward the rear of the microscope so that the reflection mirror receives unobstructed light. To do this, loosen the observation tube clamping knob and rotate the tube 180°.

1. Fit the reflection mirror in the window lens of the microscope frame by aligning the mounting tab.
2. Remove the daylight filter because it renders the image blue under natural light conditions.
3. The reflection mirror (fig. 5) should be pointed toward anywhere with stray light. While observing the image through the eyepieces, adjust the orientation of the reflection mirror to capture stray light.

A planar reflection mirror is used normally. However, if the brightness is uneven or the outside view is visible in the image, use a image concave reflection mirror.

## 3 OPTIONAL EYEPIECES

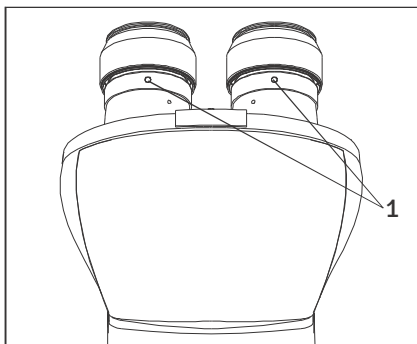

Fig. 6

The standard 10X eyepieces are clamped using screws.

1. Using allen wrench 1.5mm, loosen the clamping screw (1) from the ocular tube and remove it.
2. Insert the optional eyepieces into the ocular sleeve and tighten the clamping screw(1).

**1 OBJECTIVES**

Fig. 7

Objectives are factory set. Objectives are par-centered and parfocalised during assembly.

All objectives have been secured for a tight fit to prevent them from coming loose during transit. To remove an objective, rotate it counterclockwise while holding it with a rubber grip to avoid any slippage.

**2 OBSERVATION HEAD**

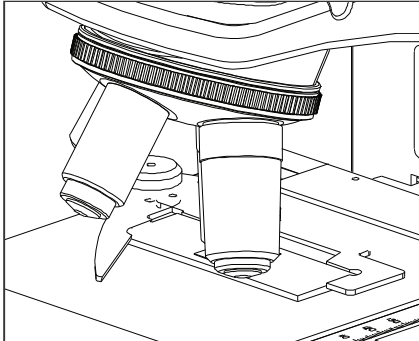
Fig. 8

Install the observation head using the following procedure:

1. Using Allen wrench 3mm (provided), loosen the Head Locking Screw (1) and remove the dust cover cap provided in dovetail Cavity as well as on observation head dovetail.
2. Mount the Observation Head by engaging the dovetail provided at the bottom of the head into the dovetail cavity provided in the microscopes arm.
3. Tighten the Head Locking Screw (1) after positioning the Observation head as desired. See figure 8.

**3 EYEPIECES**

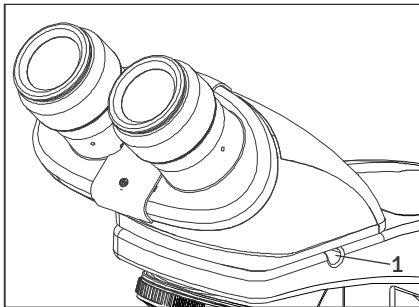
Fig.9

Insert the eyepieces into the ocular tube of Observation Head using following procedure:

1. Remove the protective caps from the observation tube.
2. Insert 10x eyepieces into the ocular sleeve and tighten the clamping screw (1) using allen wrench 1.5mm. See figure 10.

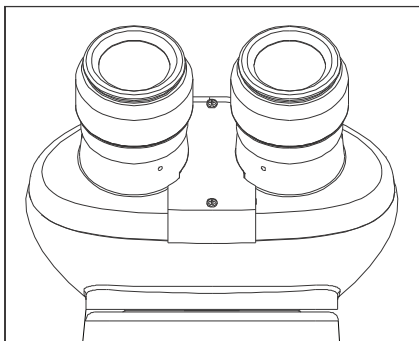
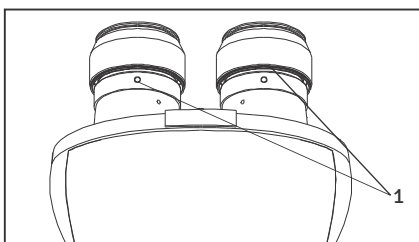

Fig.10

## REPLACEMENT OF CRITICAL COMPONENTS

Each standard set can be assembled by simply attaching the filter and power cord.

## 1 INSTALLING OR REPLACING THE LAMP BULB

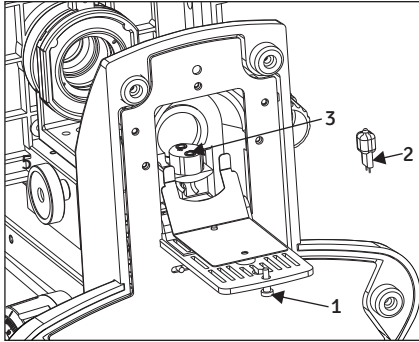

Fig. 11

Before attaching the lamp bulb, remove the parts that may drop such as the filter and specimen from the microscope frame, and place the microscope in its back so that the bottom plate is exposed.

1. Pull the lock knob (1) on the bottom to open lamp housing door (fig.11).
2. Hold the halogen bulb (2) without taking it out of the polyethylene bag so as not to taint the bulb with fingerprints and push the bulb into the pin holes on the socket (3). After attaching, remove the polyethylene bag.
3. With the lock knob pulled out, close the lamp housing door, then push the lock knob back to lock the cover.

**Applicable bulb: 6V20W Halogen bulb P/N CX-013**

Always use the designated bulb. Using a bulb other than those specified by LABOMED may lead to a fire hazard or and low illumination. Fingerprints or stains on the lamp bulb reduce its life. If contamination occurs, wipe bulb surface with a cloth slightly moistened with alcohol.

### CAUTION: For Bulb Replacement During Use or Right After Use

The bulb, lamp socket and areas near these will extremely hot during and right after use. Set the main switch to "O" (OFF), disconnect the power cord from the wall outlet, and allow the bulb and lamp socket to cool before replacing the bulb with a new bulb of the designated type. Cooling time may vary to users Discretion.

## 2 PROCEDURE FOR LED REPLACEMENT

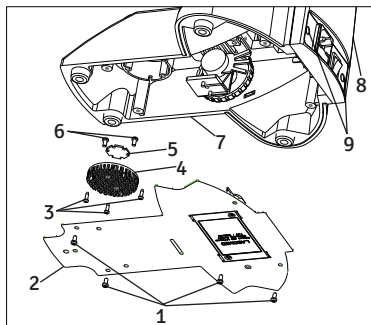

Fig. 12

1. Screws SS 658
2. Base Plate 9135100-301
3. Screws Heat Shield SS 714
4. Heat Shield 9135000-524
5. Star LED 9135000-901
6. LED Screws SS 658
7. Stand
8. Back Cover Plate 9135000-102
9. Decorative Cap 8123000-202

Figure 12

1. Pull out two decorative caps (shown as 9) from back cover plate.
2. Using Cross head screw driver, unscrew two screws (shown as 9) to detach back cover plate from stand.
3. Lay down the microscope on back cover over a clean surface to expose base plate.
4. Using Cross head screw driver, unscrew four screws (shown as 1) to open the bottom plate of the microscope.
5. Cut LED wire holding tie and Detach LED wire connector from PCM mounted on back cover plate.
6. Detach Heat Shield from critical mount by opening 3 screws (shown as 3) with cross head screw driver.
7. Detach LED from Heat Shield by loosening 3 screws (shown as 6).
8. Replace new LED on Heat Shield and connect wire connections to PCB.
9. Reverse steps 6 to 1, to complete the process.

**Applicable LED replacement: LED P/N 9135000-901**



**3 PROCEDURE FOR LED BATTERY REPLACEMENT**

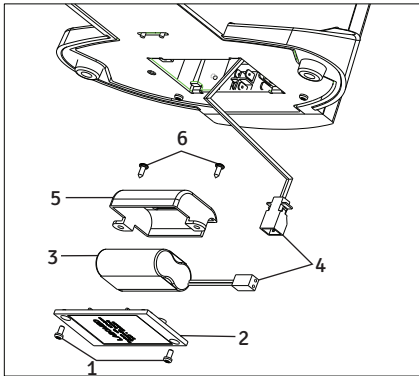

Fig. 13

- 1. Screws for Battery cover bottom SS 658
- 2. Battery cover 9135100-204
- 3. Battery 9135000-903
- 4. Cable clamp EL-488
- 5. Battery cover led 9135100-201
- 6. Screws Battery clamp SS 658

Figure 13

1. Lay down the microscope on back cover a over clean surface to expose base plate.
2. Using Cross head screw driver, unscrew four screws (shown as 1) to open the battery cover from bottom plate.
3. Detach connector of connecting wires (shown as 4)
4. Remove two screws (shown as 6) provided on battery clamp with Cross head screw driver.
5. Replace existing Battery with new battery from LABOMED (Refer part no. below)
6. Reverse steps 5 to 1, to complete the process.

**Applicable LED Battery Replacement: LED P/N 9135000-903**

**4 INSTALLING OR REPLACING THE FUSE**

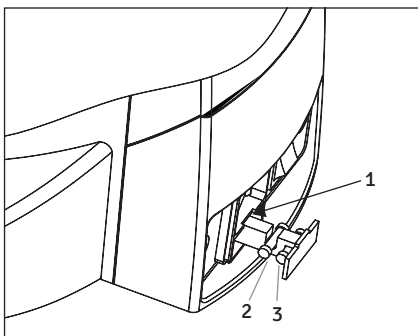

Fig. 14

Before replacing the fuse, remove the parts that may drop such as the filter and specimen from the microscope frame. Turn around the microscope to its back so that the AC inlet is visible (Fig. 14).

1. Use a flat head screw driver to open the fuse holder (Shown a 1).
2. The fuse tray will come out with live fuse (Shown as 2) and spare fuse (Shown as 3). Do not pull out the fuse tray with force as it is locked and will not be out completely.
3. Replace the primary fuse (Shown as 2) with the spare fuse.
4. Engage the fuse tray back in.

**Always use the designated Fuse. Using a fuse other than those specified by LABOMED may lead to a fire hazard.**

**CAUTION: For Fuse replacement**

Set the main switch to "O"(OFF), disconnect the power cord from the wall outlet.

## SUMMARY OF BRIGHT FIELD OBSERVATION PROCEDURE

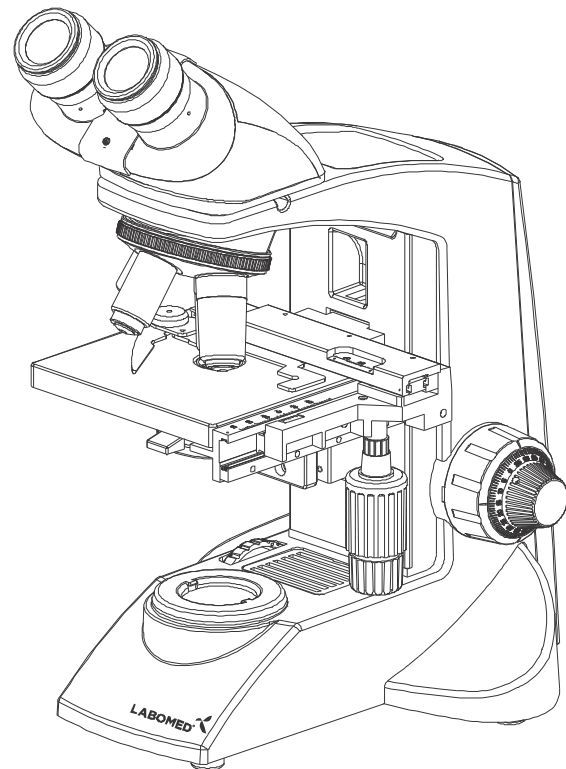
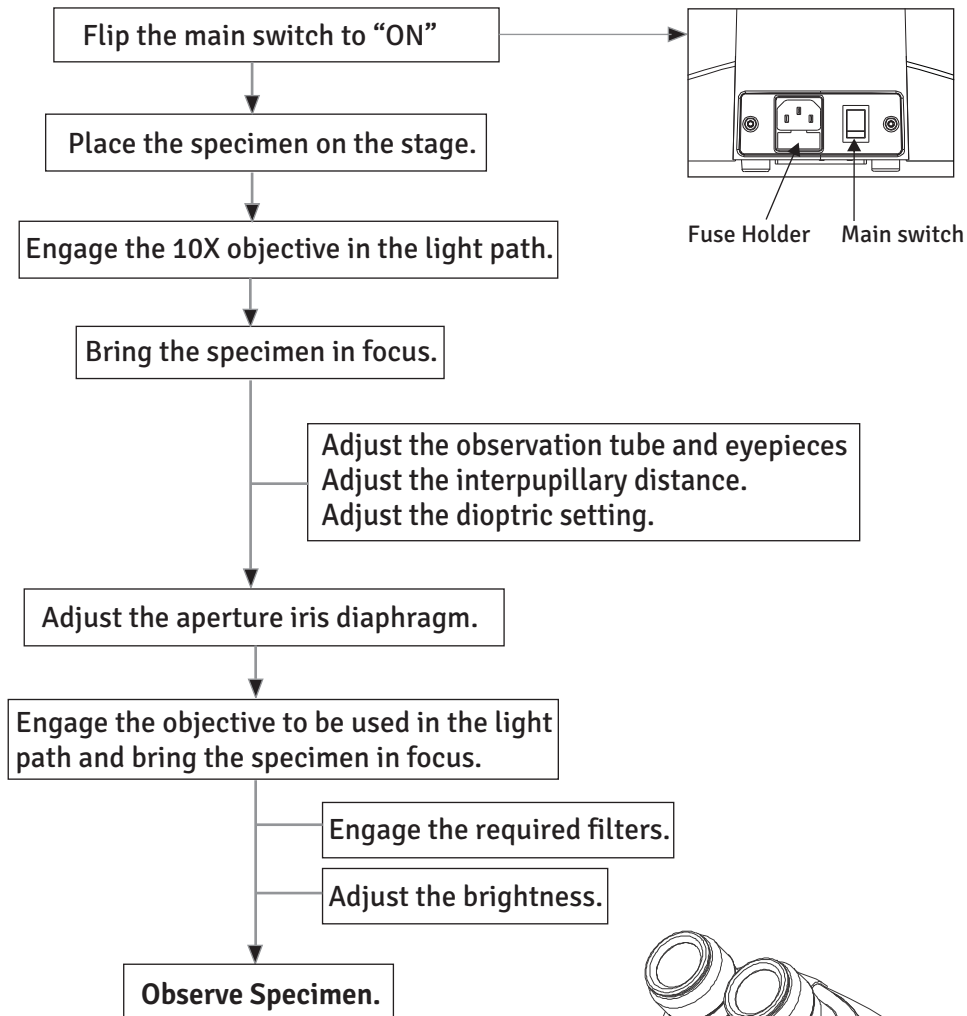

## 1 TURNING THE LAMP ON

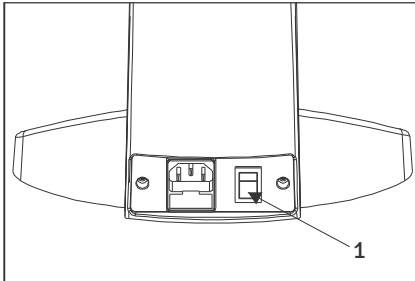

Fig. 15

1. Flip the main switch to "I" (ON) as shown in figure 15.

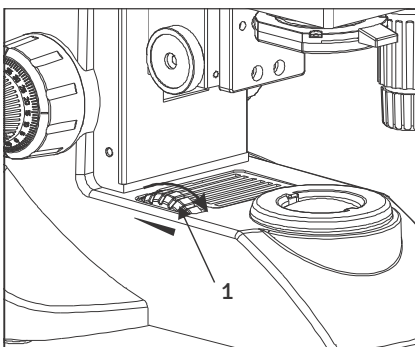

Fig. 16

2. Rotating the light intensity adjustment knob (Fig. 16) in the direction of the arrow increases brightness and rotating knob in the opposite direction decreases brightness. The intensity bar next the knob indicates the direction of intensity level.

## 2 PLACING SPECIMEN ON THE STAGE

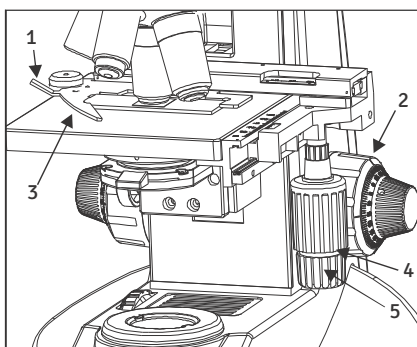

Fig. 17

Place the specimen gently on the stage. If the bow-shaped lever (3) is returned with a strong force or the control knob (1) or the bow-shaped lever is released in the middle, the slide glass may be broken. See figure 17.

1. Rotate the coarse adjustment knob (2) in anticlockwise direction to fully lower the stage.
2. Open the bow-shaped lever (3) outward by pulling on lever handle (1), place the specimen by sliding the specimen glass plate (s) on the stage from the front toward the slide seat at the rear.
3. After positioning your specimen slides, (2max) return the bow-shaped lever (3) gently by slowly releasing control knob (1).
4. Rotating the upper co-axial knob controlling the y-axis movement (4) moves the specimen in the vertical direction. Rotating the lower knob (%) moves the specimen in the X-axis or horizontal direction.

**Do not adjust the specimen holder directly by hand, for this will damage the rotary mechanisms.**

**When the specimen holder reaches stop position, the rotation force of the X/Y knobs become stiff. Stop rotating at this point.**

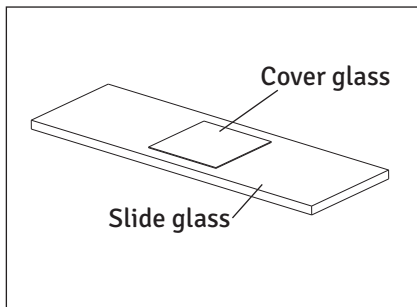

Fig. 18

**Cover glass**

This is the glass plate paced on the specimen. For optimum optical performance, the cover glass thickness, which is the distance from its surface to the specimen surface, should be 0.17mm.

**Slide glass**

This glass plate should ideally have a length of 76mm, width of 26mm ± 1mm and thickness between 0.9 and 1.4mm.

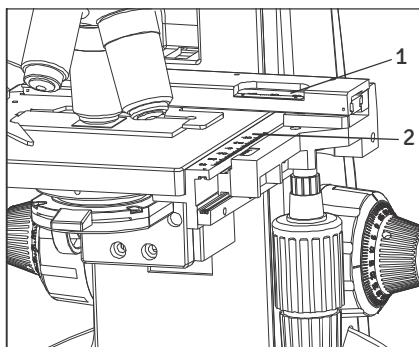

Fig. 19

**Specimen holder scales**

These scales allow for easy identification of the specimen’s position (coordinates), making it easy to return to a particular region of interest after scanning the slide.

1. The horizontal coordinate can be read at position (1) on the specimen holder. (fig. 19).
2. The vertical coordinate can be read at the index line (2).

**3 ADJUSTING THE FOCUS**

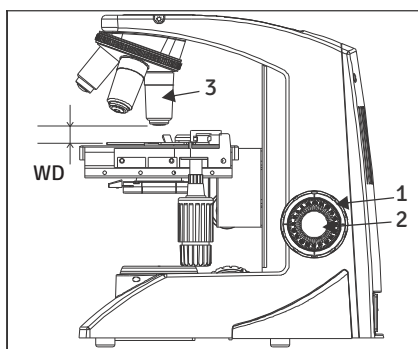

Fig. 20

**Focusing Procedure**

1. Rotate the coarse adjustment knob (1) clockwise so that the objective (3) is as close as possible to the specimen (we recommend starting with 10X). See figure 20.
2. While observing the specimen through the eyepieces, slowly rotate the coarse adjustment knob (1) counterclockwise to lower the stage.
3. When coarse focusing of the specimen is obtained (an image is observed), rotate the fine adjustment knob (2) for fine detail focusing.

**Working Distance (WD)**

The WD refers to the distance between each objective and the specimen, when acute focus of the specimen is obtained.

Objective Magnification	4X	10X	40X	100X
WD (mm)	17	6.44	0.5	0.1

#### 4 ADJUSTING THE INTERPUPILLARY DISTANCE (IPD)

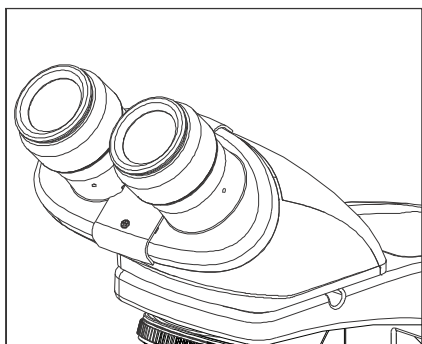

Fig. 21

The inter-pupillary distance adjustment consists of regulating the two eyepieces to align with both eyes' pupils so that you can observe a single microscope image through two eyepieces in stereo vision. This greatly helps to reduce fatigue and discomfort during observation.

While looking through the eyepieces, move both eye tubes laterally until the left and right fields of view coincide completely.

The position of index dot (•) indicated the inter-pupillary distance value.

Note your interpupillary distance so that it can be quickly duplicated.

#### 5 ADJUSTING THE DIOPTR

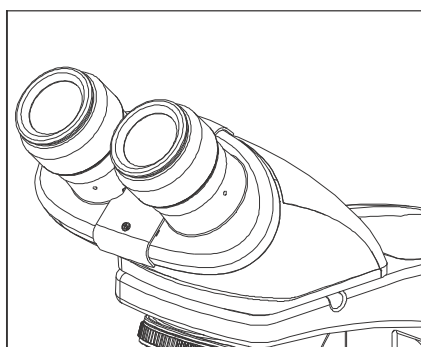

Fig. 22

Procedure for adjusting the diopter:

1. Rotate the right eyepiece to match the center of the diopter scale markings.
2. While looking through the right eyepiece with your right eye, rotate the coarse and fine adjustment knobs to bring the specimen into focus.
3. While looking through the left eyepiece with your left eye, rotate only diopter adjustment ring on the eyepiece until specimen is at its best possible focus.

This is a special feature provided to compensate the tube length change while changing IPD setting. Follow this procedure to obtain optimum parfocality of system to your IPD setting.

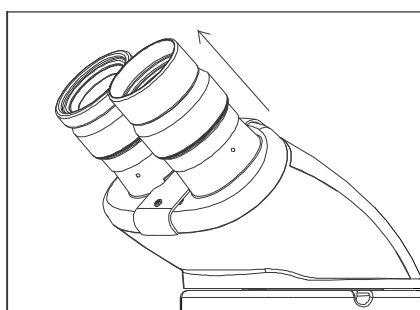

Fig. 23

#### Using the Eye Guards

##### When Wearing Eyeglasses

Use with the eye guards in the normal, folded-down position. This will prevent the eyeglasses from being scratched.

##### When Not Wearing Eyeglasses

Extend the folded eye guards outwards (direction of the arrow) to prevent ambient light entering into your line of vision.

## 6 ADJUSTING THE CONDENSER POSITION AND APERTURE IRIS DIAPHRAGM

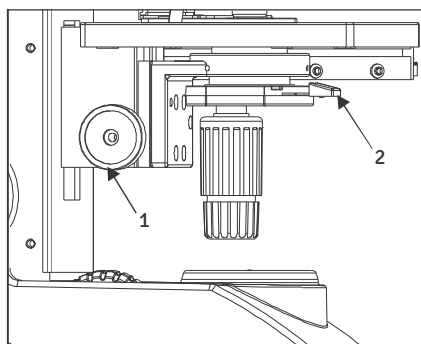

Fig. 24

The condenser is most often used in the highest position. If the observed field of view is not bright enough, brightness may be improved by lowering the condenser slightly.

Rotate the condenser height adjustment knob (1) in clockwise direction to move the condenser to the highest or desired position.

Slide the aperture iris diaphragm (2), so that the aperture of the objective in use is fully illuminated.

## 7 SWITCHING THE OBJECTIVES

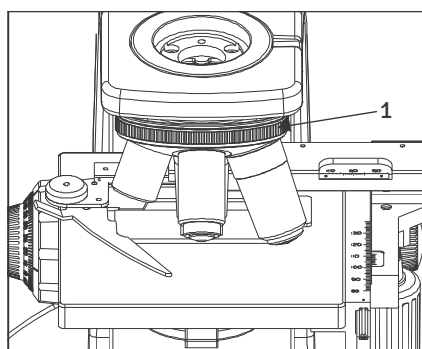

Fig. 25

Hold and rotate the revolving nosepiece (1) so that the objective to be used is in line above the specimen. Always use the ribbed grip to rotate the objective nose piece.

## 8 MOUNTING THE DAYLIGHT (BLUE) FILTER

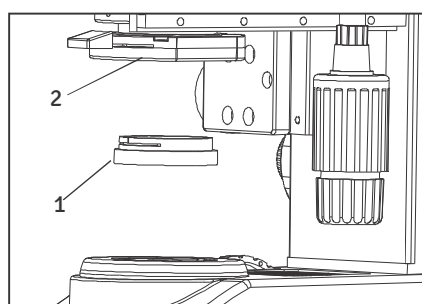

Fig. 26

This filter modifies the color of observation light into a natural color (daylight color).

- Fit the daylight filter (1) into the button of the condenser (2) until it clicks into place. See figure 26.

## 9 USING THE 100X IMMERSION OBJECTIVE

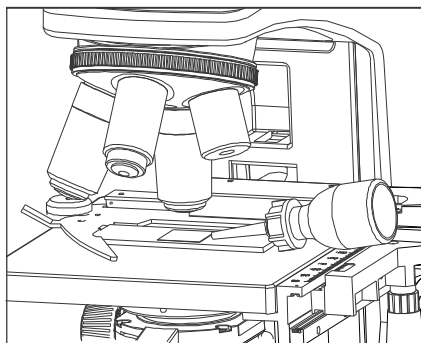

Fig. 27

The designated immersion oil should be in contact with the cover lens of the 100X immersion objective. If not, the specimen will appear distorted and dull. It is recommended that LABOMED immersion oil is always used.

### Immersion Process:

1. Bring the specimen in focus using first the 10x, then 40x objective.
2. Disengage the 40x cycling towards 100x, and place a drop of immersion oil on the center point of the specimen.
3. Rotate the revolving nose piece to engage the immersion objective and rotate the fine adjustment knob to bring the specimen into focus

**(Since air bubbles in the oil will affect the image quality, make sure that the oil is free of bubbles. To remove bubbles, rotate the revolving nosepiece slightly to agitate the oil).**

4. The condenser of this microscope manifests the full performance when oil is placed between the slide glass and the front lens of condenser. If oil is not placed there, the observed image may appear dark.
5. After use, remove oil from the objective front lens by wiping with lens tissue slightly moistened with an petroleum (85%) isopropanol (15%) mixture.

### Caution:

If immersion oil makes contact with your eyes, rinse eyes out thoroughly with fresh water. If immersion oil makes contact with skin, wash affected areas with soap and water.

If prolonged discomfort is experienced, consult your physician immediately.

Under certain conditions, performance of the unit may be adversely affected by factors other than defects. If problems occur, please review the following list and take corrective action as needed. If problem persists, please contact LABOMED or your local LABOMED dealer.

OBSERVATION	CAUSE	REMEDY
1. Uneven brightness in observation field	The objective is not engaged in the light path	Engage the objective into position until the nose turret clicks
	The condenser is too low	Raise up to achieve more light
2. Dust or stains are visible in observation field	The objective, eyepieces, condenser and/or window lens are dirty	Clean them thoroughly
	The eyepieces, condenser, window lens and/or specimen glass is dirty	Clean glass parts thoroughly with lens tissue and cleaning solution
3. Glare visible in field of view	The condenser is too low	Raise it
	The condenser iris diaphragm ring is closed	Adjust the aperture according to the objective magnification
4. Observation image is hazy or unclear	The objective is not engaged in the light path	Engage the objective into position until it clicks
	The objective, eyepieces, condenser and/or specimen glass is dirty	Clean glass parts thoroughly
	Immersion oil is not used with an immersion objective	Use immersion oil as suggested
	Bubbles are present in immersion oil	Remove the bubbles by agitation
	The specified immersion oil is not used	Use the immersion oil supplied by LABOMED
5. Part of image is defocused	The objective is not engaged in the light path	Engage the objective into position until the nose turret clicks
	The specimen is not set properly on the stage	Set the specimen correctly on the stage and secure using the specimen holder
6. Coarse focus adjustment cannot lower the stage low enough	The condenser is too low	Raise the condenser
7. Fields of view through both eyepieces is inconsistent	The interpupillary distance is not adjusted properly	Adjust IPD
	Dioptric compensation for the two eyes is not set	Adjust it correctly
	The left and right eyepieces are of different magnification	Replace one of them so that the left and right eyepieces are identical



OBSERVATION	CAUSE	REMEDY
8. Objective hits the specimen when an objective is switched to a higher magnification objective	The specimen slide is upside down	Set the specimen correctly with the cover glass facing upwards
	The cover glass is too thick	Use a cover glass with thickness of 0.17mm
	The stage is raised too high	Lower the stage
	The slide has slipped from the slide holder	Re-position the slide in the slide holder
	Slide is of excessive thickness	Use slides with thickness between 0.9 and 1.4mm
9. Bulb/LED does not turn On	Bulb/LED is not mounted	Attach a bulb/LED
	Bulb/LED is blown	Replace the bulb/LED
	The power cord is unplugged/ Not firmly secured	Plug it securely
	Fuse is blown	Check and replace with live fuse
	Battery is low	Charge battery
10. Bulb/LED blows easily	The specified bulb/ LED is not used	Replace with the specified bulb/LED
11. High-magnification objective touches specimen just before coming into focus	The specimen is upside down	Set the specimen correctly with the cover glass on the top

# 14 SPECIFICATIONS

1. Illumination	Built-in illumination system Halogen/ LED			
2. Focusing mechanism	Stage height adjustment mechanism Fine adjustment scale: 3.0µm per graduation Fine adjustment stroke: 0.3mm per turn Total stroke: 12.7mm Co-axial coarse and fine focusing on ball drive			
3. Revolving nose piece	Quadruple positions fixed (Reverse angle)			
4. Observation tube		Monocular	Binocular	Trinocular
	Field number	18	18	18
	Tube tilting angle	45°	45°	45°
	Interpupillary distance adjustment range	NA	54-74	54-74
5. Stage	Size	167 X 124mm (with mechanical stage)		
	Movement range	76 x 50mm		
	Specimen holder	Holds a single specimen		
6. Condenser	Type	Abbe condenser (daylight filter detachable)		
	N.A.	1.25		
	Aperture iris diaphragm	Built-in		
7. Dimensions & Weight	255.0mm (L) x 227.0mm (W) x 375.23mm (H)			
8. Electrical	LED Battery	7.4V, 1500mA		
	Charging time	Upto 5 hours (with totally consumed battery)		
	Total battery time	Upto 2 hours after fully charging		
9. Operating environment	Indoor use Altitude: Max. 2000 meters Ambient temperature: 5° to 40°C (41° to 104° F) Maximum relative humidity: 80% for temperature up to 31°C (88°F), Decreasing linearly through 70% at 34°C (93°F), to 50% relative humidity at 40°C (104°F) Supply voltage fluctuations: Not to exceed ±10% of the normal voltage. Pollution degree: 2 (in accordance with IEC60664) Installation/Over voltage category: II (in accordance with IEC60664)			

## Revision History

Rev. No.	Date of Release	DCR #	Change	App. By
1.4	March 27,2019	DCR/08/19	System Diagram	S. Bal
1.5	01 June,2020		Disinfection	S. Bal
1.6	26 April,2021	DCR/13/21	Eye Pc Locking screw changed from 2.5 to 3.0mm	S. Bal
1.7	April 14, 2022	DCR/06/22	Reviewed & Updated for typo error	S. Bal



**Labo America Inc.**  
920 Auburn Court  
Fremont, CA  
94538  
U.S.A.

Phone: 510-445-1257

Fax: 510-991-9862

E-mail: [sales@laboamerica.com](mailto:sales@laboamerica.com)

[www.laboamerica.com](http://www.laboamerica.com)

**EU**REP.

**Labomed Europe**

Essebaan 50

NL-2908 LK Capelle a/d IJssel

The Netherlands

Tel: +31 (0)10 4584222

Fax: +31 (0)10 4508251

E-mail: [info@labomedeuropa.com](mailto:info@labomedeuropa.com)

**CE**



**DQS Inc.**

Labo America Inc.  
Registered to ISO 9001:2015  
BR Number 10005565